



**GUAM POWER AUTHORITY**  
 P.O. BOX 2977 HAGATNA, GUAM 96932-2977  
 PREPARED BY ENGINEERING DEPARTMENT

TRAFFIC RATED  
 2' x 4' x 3' CONCRETE  
 SECONDARY HANDHOLE

REF. 2102-TRAFFIC.1

REV. 0

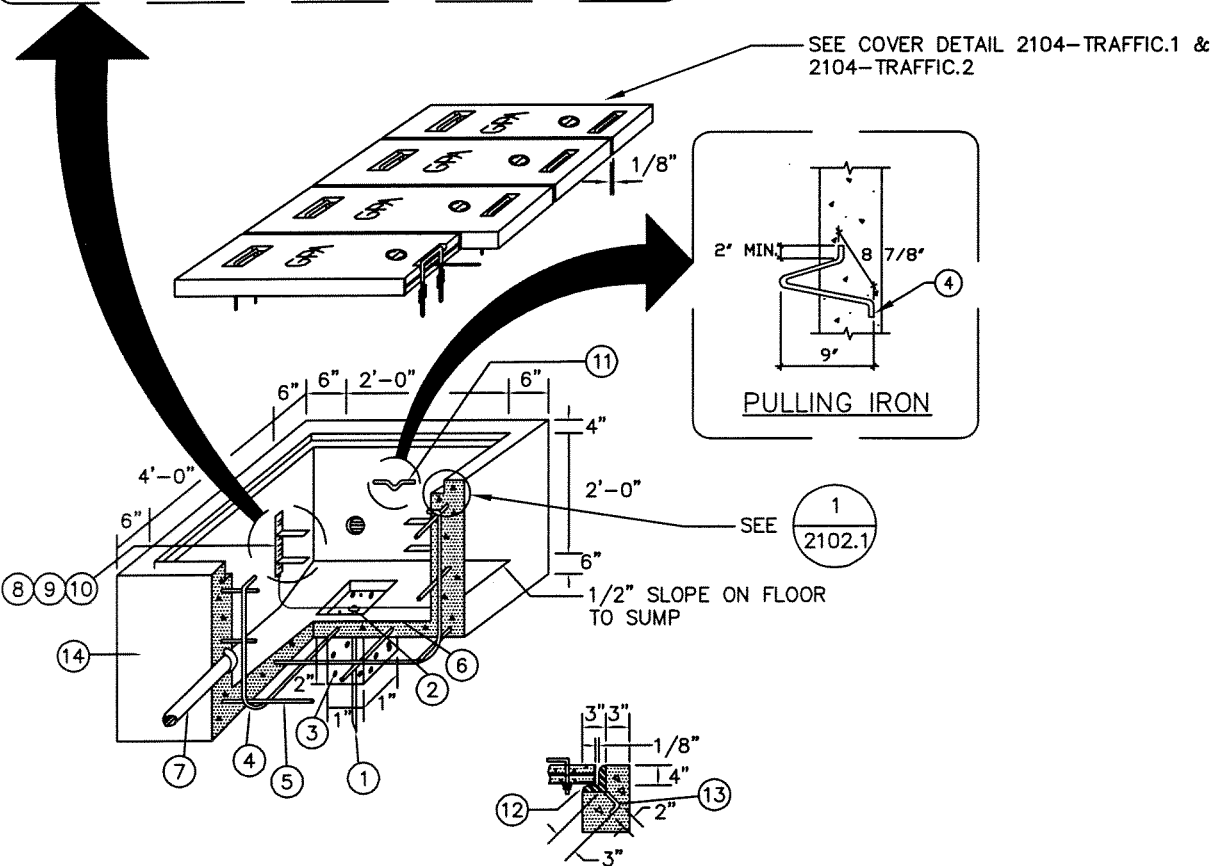
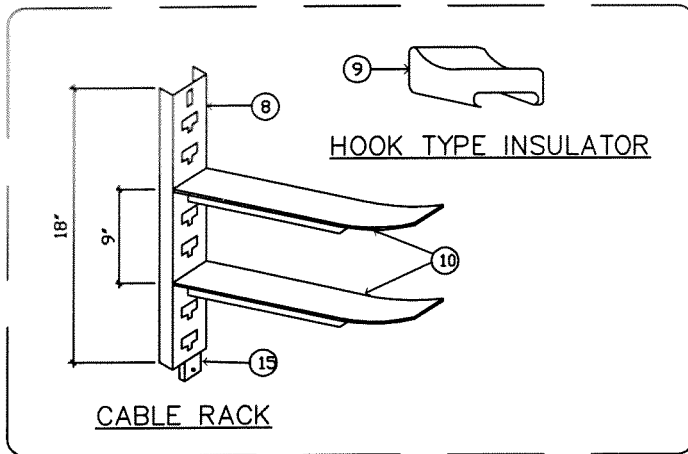

1 ANGLE IRON  
 2102.1 NOT TO SCALE

A SECONDARY HANDHOLE  
 2102.1 SCALE: NONE

EFFECTIVE DATE: 9/19/05

ISSUED: *[Signature]*

APPROVED: *[Signature]*



**GUAM POWER AUTHORITY**  
 P.O. BOX 2977 HAGATNA, GUAM 96932-2977  
 PREPARED BY ENGINEERING DEPARTMENT

TRAFFIC RATED  
 2' x 4' x 3' CONCRETE  
 SECONDARY HANDHOLE

REF. 2102-TRAFFIC.2

REV. 0

**NOTES:**

1. COORDINATE LAYOUT AND EXACT DIMENSIONS WITH GPA ENGINEERING PRIOR TO INSTALLATION.
2. THIS TYPE OF HANDHOLE IS TO BE USED IN AREAS SUBJECT TO VEHICULAR TRAFFIC.
3. GROUND ALL HARDWARE IN THE HANDHOLE.
4. TOP OF THE HANDHOLE SHALL BE FLUSH WITH THE SIDEWALK SURFACE, OTHERWISE THERE SHOULD BE A 2" CLEARANCE FROM THE FINISHED GROUND SURFACE.
5. AREA OF CONDUIT ENTRANCES SHOULD BE 6" MINIMUM FROM THE FLOOR SLAB, 10" MINIMUM FROM THE LEFT OR RIGHT SIDE WALL, AND 15" MINIMUM FROM THE TOP OF THE HANDHOLE.
6. PROVIDE APPROXIMATELY  $\frac{1}{8}$ " CLEARANCE BETWEEN HANDHOLE COVERS AND BETWEEN COVERS AND LEDGE SIDES.

ITEM	BILL OF MATERIALS
①	5/8"φ X 8'-0" COPPER WELD GROUND ROD
②	5/8"φ COPPER GROUND ROD CLAMP
③	3/4"φ MAXIMUM GRAVEL SIZE, FILL TO FINISH FLOOR
④	#4 REBAR AT 10" O.C. VERTICAL
⑤	#4 REBAR AT 10" O.C. VERTICAL
⑥	#6 COPPER WIRE (SOLID) FOR GROUNDING HARDWARE
⑦	CONDUIT WITH END BELL 6" FROM FLOOR SLAB, SIZE AND QUANTITY AS REQUIRED
⑧	CABLE RACK HOT DIP GALVANIZED
⑨	HOOK TYPE INSULATOR
⑩	INSULATOR WELDED SUPPORT
⑪	PULLING IRON 7/8"φ GALVANIZED, LOCATED AT OPPOSITE END OF EACH CONDUIT ENTRANCE
⑫	4" X 4" X 3/8" ANGLE IRON HOT DIP GALVANIZED
⑬	3/8"φ STEEL ROD WELDED TO FRAME EVERY 12" O.C.
⑭	6" THICK CONCRETE FLOOR SLAB AND WALL AT 4000 PSI YIELD STRENGTH OF 60,000 PSI FOR REBARS
⑮	SLOT FOR 1/2" BOLT AND LEAD ANCHOR

EFFECTIVE DATE: 9/19/05

ISSUED: *[Signature]*

APPROVED: *[Signature]*